

S.O. DIMM Connectors



Features/Benefits

SERIES 6401

Series 6401 is a right-angle SMT connector, conforming to JEDEC MO-160 standard of S.O. DIMM.

TECHNICAL SPECIFICATIONS

Application:	RA SMT Plastic Latch	DW Voltage:	500V rms/min.
Pitch:	1.27mm (0.050)	Contact Material:	Phosphor Bronze
Number of Contacts:	72	Insulator Material:	LCP
Height:	5.5mm (0.217)	Operating Temperature:	-55°C~85°C
Current Rating:	0.5A Max.		95% Max.
Voltage Rating:	125V Max.	Standard:	JEDEC MO-160
Mating Cycles	25		

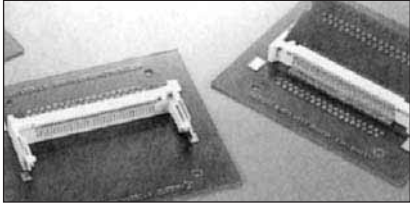

SERIES 6402

Series 6402 is a right-angle SMT connector, conforming to JEDEC standard of 8-byte S.O. DIMM. It is a low cost type connector with plastic latch and has a wide variety of profile height (4.0/5.2/5.6mm). Memory modules are firmly inserted and locked by two simple latches.

TECHNICAL SPECIFICATIONS

Application:	RA SMT Plastic Latch	Voltage Rating:	25V Max.
Pitch:	0.8mm (0.031)	DW Voltage:	1000V rms/min.
Number of Contacts:	144	Contact Material:	Phosphor Bronze
Height:	4.0mm (0.157)	Insulator Material:	LCP
	5.2mm (0.205)	Operating Temperature:	-55°C~85°C
	5.6mm (0.220)		95% Max.
Current Rating:	0.3A Max.	Standard:	JEDEC MO-190
Mating Cycles	25		

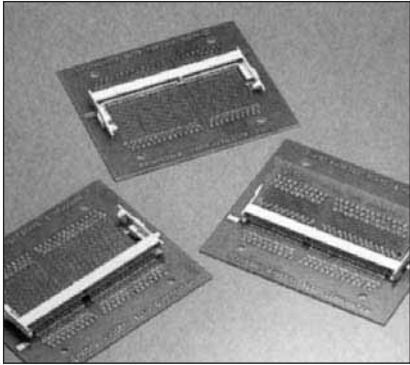

SERIES 6403

Series 6403 is a 144 positions straight SMT connector conforming to JEDEC standard of 8-byte S.O. DIMM and by both SMT and DIP type (Through Hole type).

(1) SMT and DIP are 3.3V and 5.0V type, respectively. They are also available with and without boss.

(2) SMT type, whose attachment locations of metals on the left and right side are asymmetrically arranged, is equipped with strain reliefs to improve the peeling strength to the board.

TECHNICAL SPECIFICATIONS

Application:	ST SMT/DIP	Contact Material:	Phosphor Bronze
Pitch:	0.8mm (0.031)	Insulator Material:	LCP
Number of Contacts:	144	Operating Temperature:	-55°C~85°C
Current Rating:	0.3A Max.		95% Max.
Voltage Rating:	25V Max.	Standard:	JEDEC MO-190
DW Voltage:	1000V rms/min.		
Mating Cycles	25		

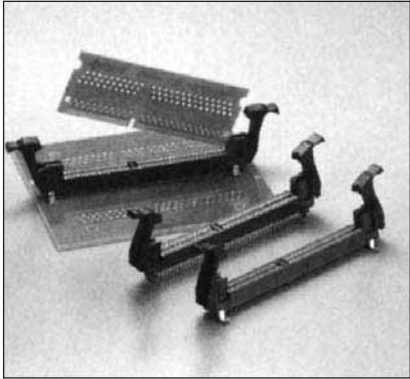

S.O. DIMM Connectors

Series 6401 72P Right Angle SMT



H=5.5MM

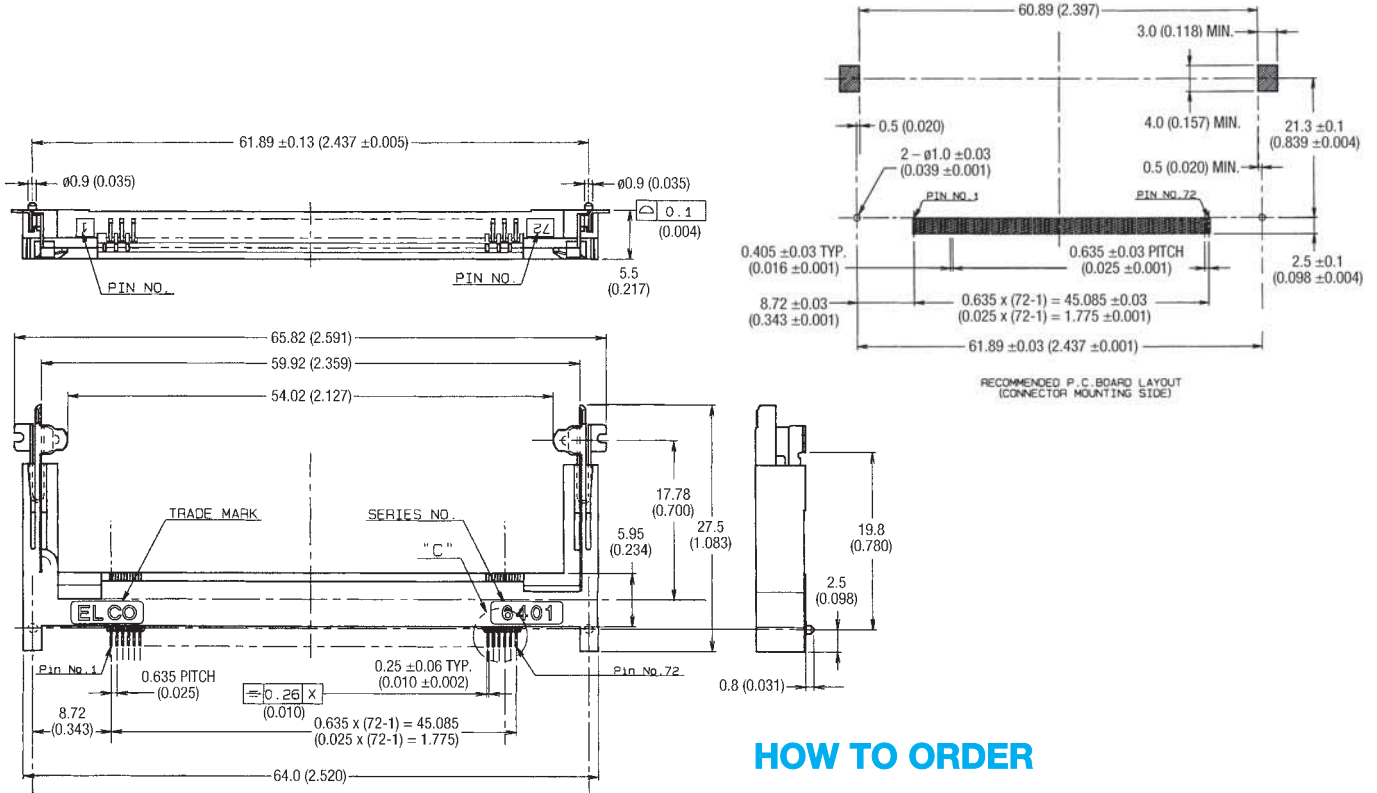

HOW TO ORDER

29 6401 072 001 856

QUANTITY: 30/TRAY
360/BOX

TRAY/PACKAGE

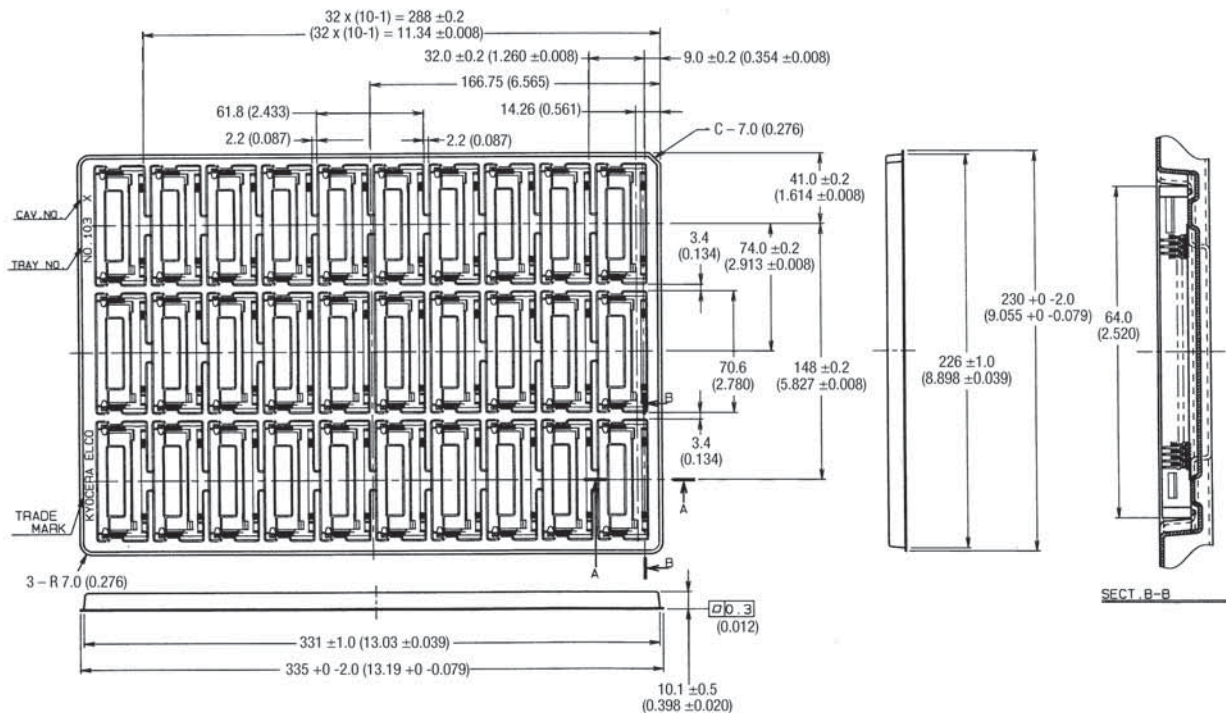

Notice

The memory board shall be inserted and separated correctly, according to direction and process as shown below.

RIGHT ANGLE TYPE (6401/6402)

Method of Insertion

1. The memory board shall be inserted completely.
2. It shall be rotated.
3. It shall be pushed into the latch on both sides from upward.

Method of Separation

4. The latch on both sides shall be unlocked.
5. After the memory board rises, it shall be extracted.

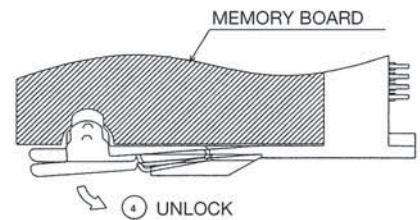
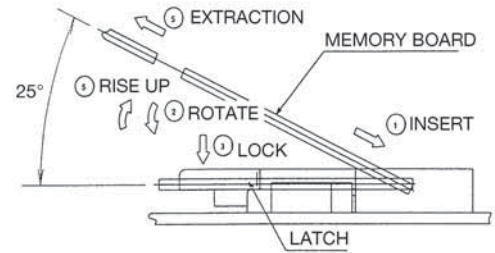

STRAIGHT TYPE (6403)

Method of Insertion

1. The lever on both sides shall be unlocked and memory board shall be inserted.
2. The memory board shall be inserted even the latch on both sides shall be locked.

Method of Separation

3. The lever on both sides shall be unlocked.
4. The memory board shall be extracted.

